

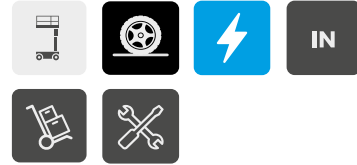

## STAR 6 PICKING



### SAFETY FIRST

- > Double "lambo" doors, dedicated anti-slip steps and walkable plinths
- > Picking tray with foldable side panels & front guard rail
- > High-precision driving and smoothness with maximal driving visibility
- > Quick machine with mobile pothole protections

### GO EVERYWHERE, ANYTIME

- > Maximum load of electric picking tray: 80 kg
- > Intuitive upper control box with battery level indicator
- > Smart transportability & lifting

### WITH THE BEST VALUE FOR MONEY

- > 3-stage-cylinder mast: no chain and no cable
- > Direct electric drive (maintenance-free) AC motors
- > Easy access to components (2 swing out trays)
- > Haulotte Activ'Screen (onboard diagnostic)

# STAR 6 PICKING

## VERTICAL MASTS

### TECHNICAL DATA

### STAR 6 PICKING

Working height	5.8 m
Platform height	3.8 m
Lift capacity - inside	210 kg (1 pers.)
Picking tray lift capacity	80 kg
<b>A</b> Length	1.65 m
<b>B</b> Width	0.79 m
<b>C</b> Height - stowed	1.75 m
<b>D</b> Wheelbase	1.07 m
<b>E</b> Ground clearance	6 cm
Platform size	0.76 x 0,92 m
Picking tray size	0.74 x 0.50 m
Drive speed proportional	0.8 - 4.5 km/h
Turning radius - outside	1.7 m
Tilt alarm	1.5 ° / 3 °
Gradeability	25 %
Driveable at full height up to	3.8 m
Tyres - non marking	318 x 108 mm
Power source	6V - 180 Ah (C5)
Weight	890 kg

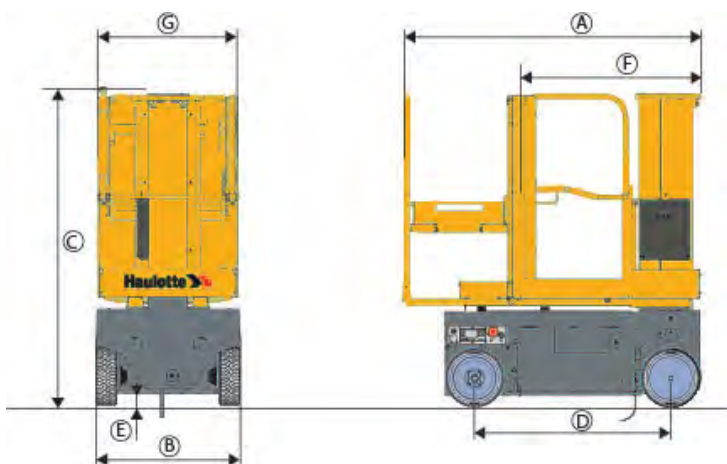

### STANDARD EQUIPMENT

- > Electric picking tray with foldable side panels & front guard rail
- > 24 V electric drive brushless AC motors (free maintenance)
- > 4 x 6 V - 180 Ah batteries
- > 30 A battery charger
- > Battery level indicator
- > Haulotte Activ'Screen
- > Fork lifting pockets
- > Hoisting and lifting points
- > Electric brake release
- > 2 "lambo" doors
- > Protection baseboards
- > Mobile potholes
- > 2 front steering wheels
- > 2 rear driving wheels
- > Non marking tires
- > Hourmeter
- > Horn
- > Travel alarm
- > Flashing light
- > Emergency stop
- > Lowering system
- > 2 upper control boxes (one is mobile)
- > Control boxes at cage and ground level
- > Towing hook

### OPTIONS AND ACCESSORIES

- > Order / stock picker equipment
- > Biodegradable oil
- > Hydraulic oil for cold conditions
- > Telematics ready
- > Pedestrian warning light
- > Double flashing light

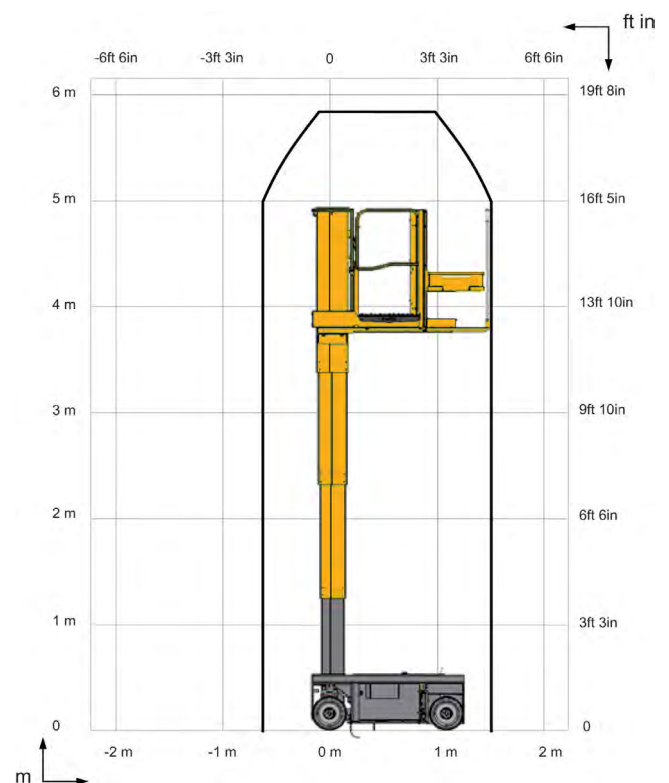

2420342590 - Non contractual document - We reserve the right to modify the technical characteristics of this document without notice - 09/2018